

For Product Step File or 3D Model Send a Request Mail To info@nrack.com

RL

Photo View



MS 502-2-1R MS 502-2-1W

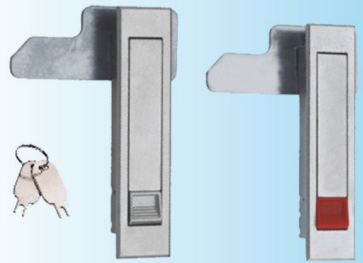

MS 502-2-2W MS 502-2-2R

3D Rendered View

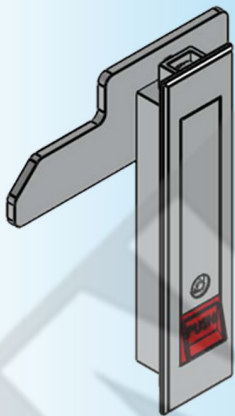

MS 502 - 2

- Material: Zinc die-casting body, Zinc plating cam
- Finish: Pocked chrome plating
- Panel thickness: 1~4mm

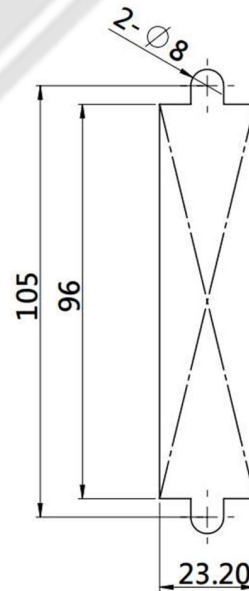
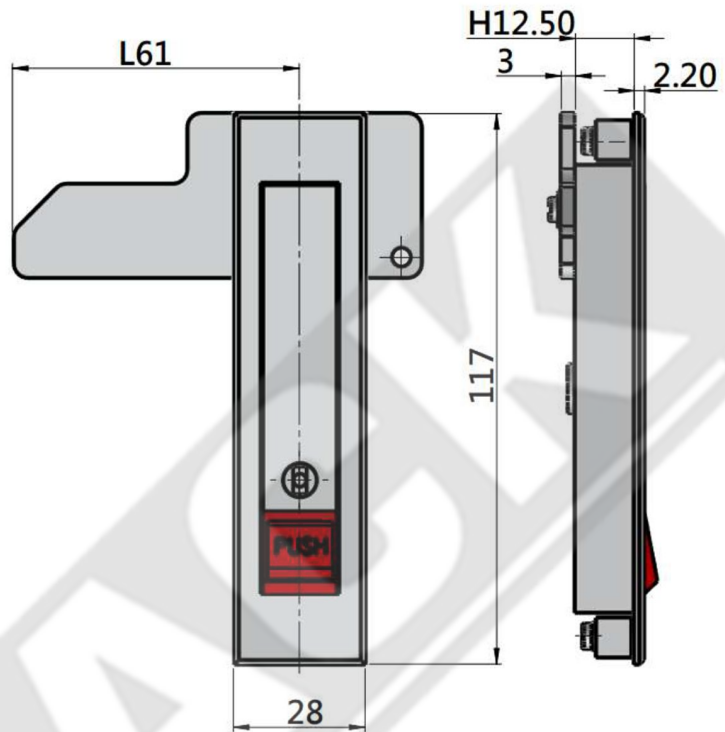

CUT OUT

Product Number		Weight (g)	Lot	
White button	with key	MS 502- 2- 1W	149	100
	w/o key	MS 502- 2- 2W	149	100
Red button	with key	MS 502- 2- 1R	149	100
	w/o key	MS 502- 2- 2R	149	100